



WFF 150 Vortex Filter Operation & Maintenance

Overview

The Wisy WFF 150 Vortex Filter harvests up to 95% of the rooftop rainwater runoff from a roof area up to 5,500 sq.ft. Particulate is separated and diverted from the rainwater through the vortex action to protect the harvested water quality prior to entering the storage tank (cistern). The WFF 150 Vortex Filter can be used in above or below ground installations where multiple downspouts are connected to a single trunk line. The trunk line feeds into the centrally located Vortex Filter.

Components (see page 4 for illustration)

Housing: polypropylene

Lid: polypropylene

Filter insert: stainless steel 280 micron pore size

Handle: stainless steel 12' standard

Extension (for below ground installation only): polypropylene

Mounting bracket (for above ground installation only): stainless steel (*sold separately*)

Installation

Above ground: Connect and divert all downspouts to a 6" trunk line to the vortex filter. Use 1/8" fall per linear foot of piping to ensure gravitational flow to the filter.

Securely attach mounting bracket to a solid, level wall area. Arrange provided hardware as shown in the picture. Align the hole on the bottom of the vortex filter with the bolt on the bottom of the mounting bracket. Attach bracket around vortex filter, ensuring filter is level.

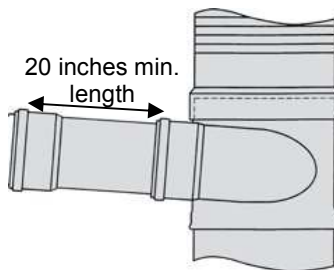

Connect 6" thin wall sewer and drain (S&D) piping* to the inlet of the filter. Plumbing lubrication may be necessary to insert the S&D pipe into the intake gasket of the filter. Ensure there is at least 20 inches of flat pipe to calm water before entering the filter. Failure to do so will decrease filter efficiency. Wisy filters are made in Germany, thus the filter connections are in millimeters and require a ferncoat fitting (not included, but available from RMS) to make the 4" connection to the tank. Connect the rubber ferncoat fitting to the 4" outlet to tank to ensure proper fitting of 4" thin wall sewer and drain pipe to filter. Connect the bell end of a 6" thin

wall S&D pipe over the stormwater outlet or use a 6" ferncoat fitting to connect the pipe. Make remaining connections to the tank and to storm drain area, preferably a pervious area on-site.

Below ground: Connect and divert all downspouts to the vortex filter in 6" pipe. Determine location of vortex filter to ensure gravitational flow will occur from piping to filter and finally to the tank.

Create a level and stable platform for which the filter can sit. A level concrete stepping stone is a recommended option. Connect 6" thin wall sewer and drain (S&D) piping* to the inlet of the filter. Plumbing lubrication may be necessary to insert the S&D pipe into the intake gasket of the filter. Ensure there is at least 20 inches of flat pipe to calm water before entering the filter. Failure to do so will decrease filter efficiency. Wisy filters are made in Germany, thus the filter connections are in millimeters and require a ferncoat fitting (not included, but available from RMS) to make the 4" connection to the tank. Connect the rubber ferncoat fitting to the 4" outlet to tank to ensure proper fitting of 4" thin wall sewer and drain pipe to filter. Connect the bell end of a 6" thin wall S&D pipe over the stormwater outlet or use a 6" ferncoat fitting to connect the pipe. Make remaining connections to the tank and to storm drain area, preferably a pervious area on-site.

Use the provided polyethylene extension to bring the filter lid to just above grade to prevent surface water from entering. Trim off excess with a hand saw. Screw lid on to the extension with the provided stainless steel screws. For deeper depths, a maximum of three (3) extensions can be used.

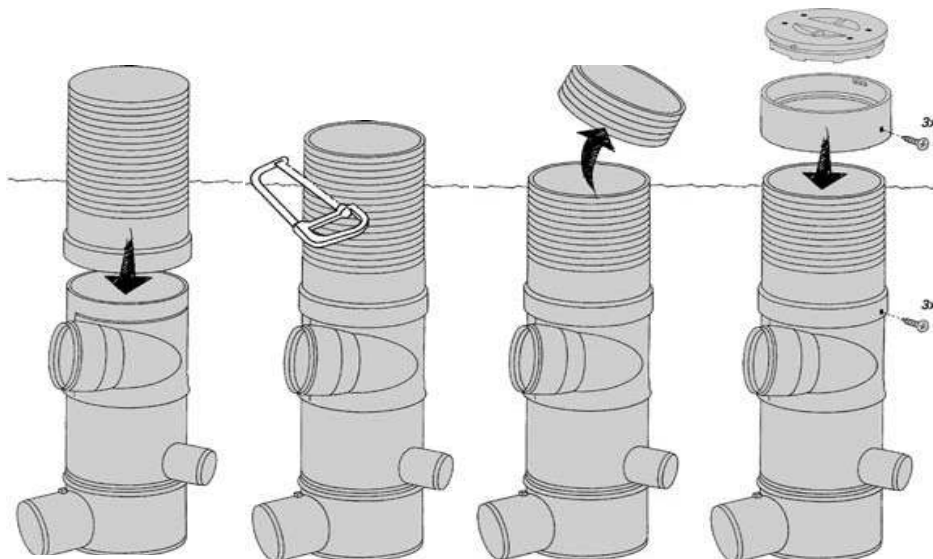

Note: ensure lid is never obstructed or buried. Access is necessary for maintenance.

Note: vortex filter inlet and outlets rotate to fit installation needs.

Notes: longer filter handles are available from RMS for deeper installations.

Maintenance

Inspect stainless steel filter insert every six months. If needed, remove filter with included handle and wash with a garden hose or in a dishwasher. The stainless steel filter insert will never need replacing, if maintained as directed.

New construction: check filter more often as building material debris may accumulate in the filter.

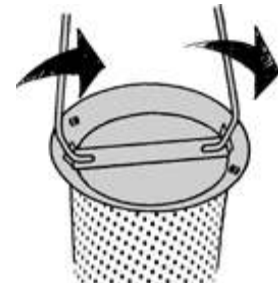

* If S&D pipe is not available, schedule 40 pipe can be used with a ferncoat. If schedule 40 pipe is used for the filter inlet, the gasket must be removed to allow water to flow smoothly into the filter.

WFF 150 Vortex Filter Components

