

WISY Vortex fine filter (WFF 300)

For industrial and commercial rainwater harvesting

Please read these instructions carefully before installing the WISY Vortex fine filter.

Instructions for installation and use

Area of application

The WISY Vortex fine filter (WFF), is intended for installation below ground. There, connected to a horizontal drain pipe, it filters the roof area rainwater which is then transferred to a cistern.

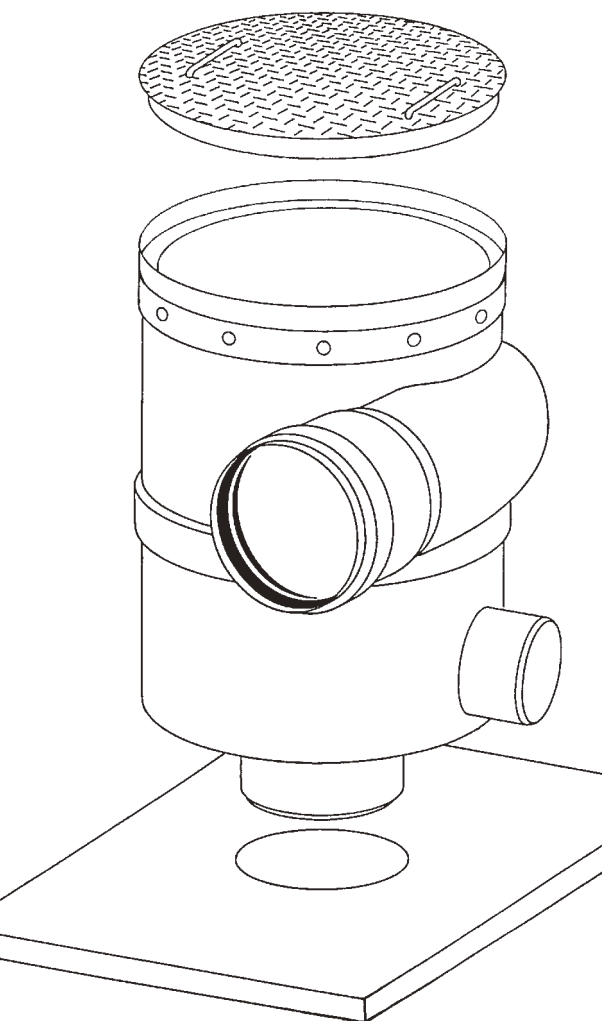

- Fitted to a horizontal drain pipe, the WFF filters and diverts the rainwater to a storage cistern. The incoming rainwater runs out of the horizontal drain pipe into the side of the WFF and is then led in a **vortex** to the filter housing below. There the rainwater is drawn through the vertically placed **fine filter** by adhesion and is led through the outlet to the storage cistern, whilst the dirt is rinsed away with the remaining water into the drain. More than 90% of the rainwater entering the WFF is filtered and collected by this principle.

- Particles larger than 0.38 mm are directly rinsed away into the drain.

- The full cross-section of the rainwater drainage system remains continuously open in the WFF system. There are no restrictions or obstructions in the appliance on which debris can collect. This is especially important in hail storms and torrential rainfall. In such cases 50% of the filtered water is still transferred to the storage cistern. Excess rainwater is led directly to the rainwater drain or soakaway.

- The WFF meets the requirements of the German standard DIN 1986 (drainage of buildings and property).

- The filter element develops its maximum efficiency when its filter mesh has been completely wetted. Only then does it reach its maximum efficiency. After a dry period this can take up to 2 minutes.

- Pitched roofs with slate, clay or concrete tiles are most suitable for collecting the rainwater. Planted roof areas are less suitable because of the low water-collection efficiency and the brown colour imparted into the collected water. Non-sealed **asbestos cement roofs are less suitable**; the fibres of this roof covering tend to block the fine filter mesh.

- With the optional blind insert (accessory) the collection and filtering of the appliance can be stopped. The rainwater from the roof then flows directly into the drain (for maintenance etc.).

- If necessary (for deeper underground installation) an extension pipe can be installed up to ground level (accessory).

- The rainwater inlet can be turned 360° in relation to the lower part. The central drain outlet is vertical so that pipes can be connected in any direction.

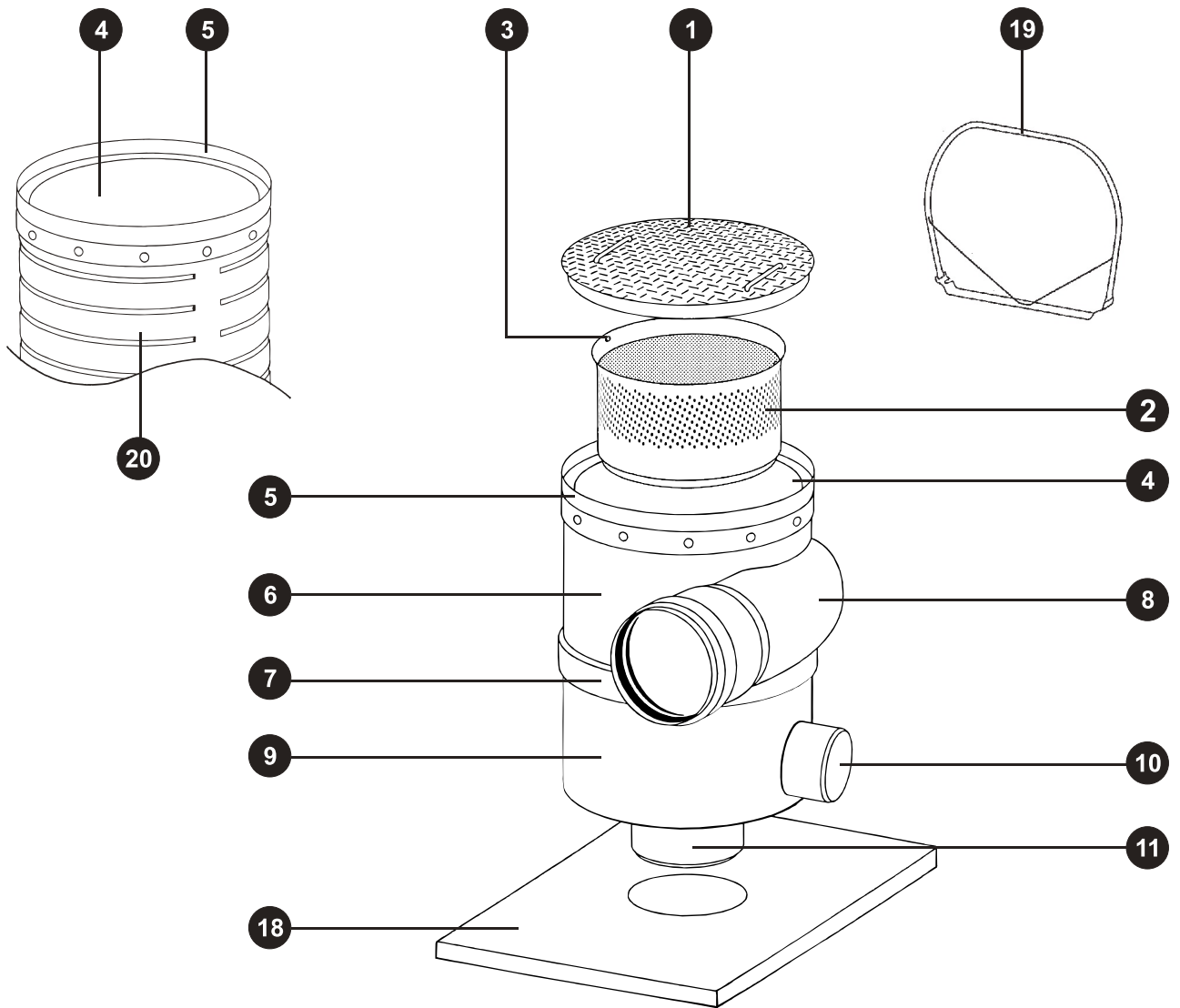

Components

- 1 heavy duty steel cover
- 2 filter element
- 3 lifting lug
- 4 opening
- 5 locating ring for lid or extension tube
- 6 upper housing
- 7 housing ring
- 8 rainwater inlet
- 9 lower housing
- 10 filtered water outlet
- 11 waste water outlet
- 12 deflecting ribs
- 13 stream in level
- 14 clean water collection ring
- 15 safety
- 16 inlet seal
- 17 filter element seal
- 18 steel baseplate
- 19 filter element lifting handle
- 20 extension tube (accessory)

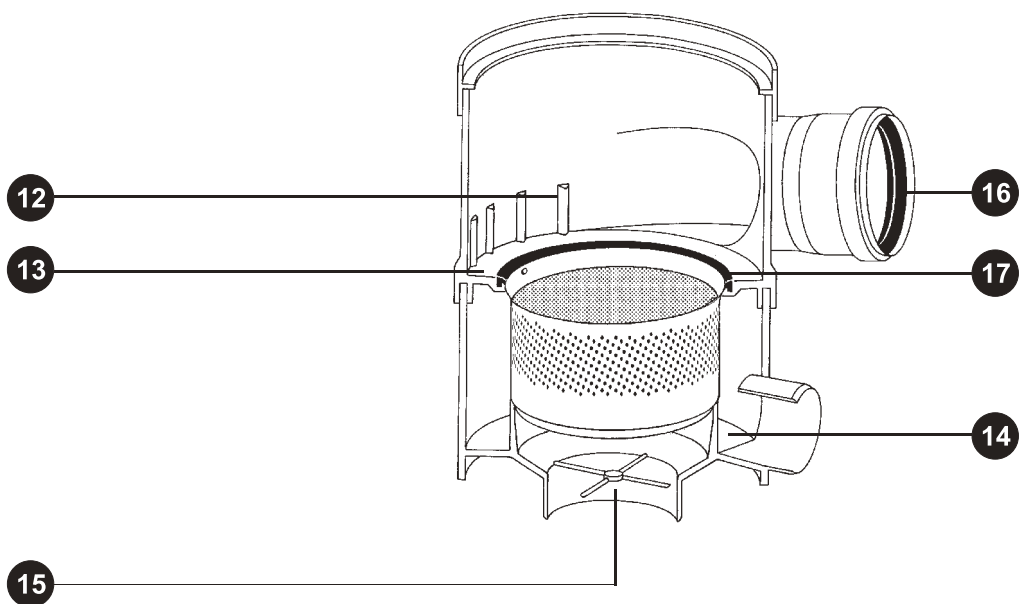

Technical data

Drained area:	3000 sq.m.
Filter capacity:	16 litres/second
Housing parts:	Polypropylene
Seals:	Rubber
Filter insert and mesh;	Stainless-steel 1.4301
Mesh size of the filter mesh:	0.38 mm
Rainwater inlet:	DN 300*
Tank outlet:	DN 200
Drain outlet:	DN 300
Lifting handle:	Stainless-steel 1.4301
Weight:	95 kg
Cover load:	carries vehicles of up to 60 t, tested in accordance with German standard ATV guiding rules
Acid-resistant:	Yes
Groundwater neutral:	Yes

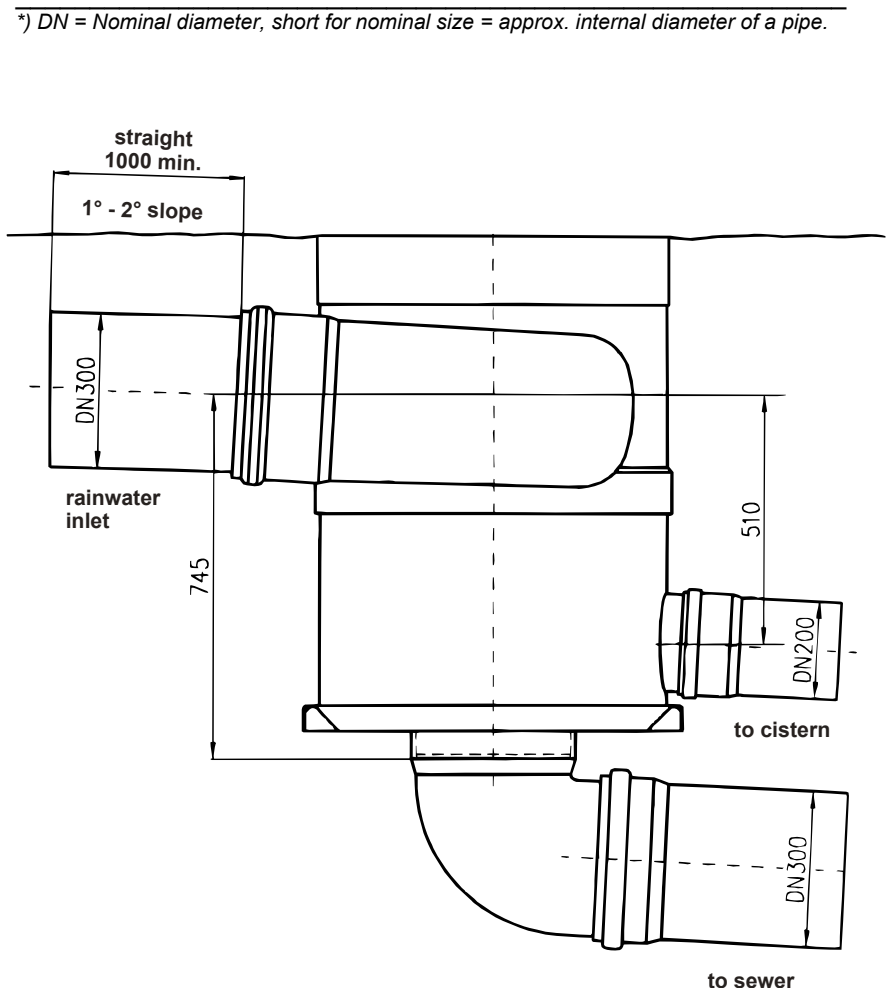
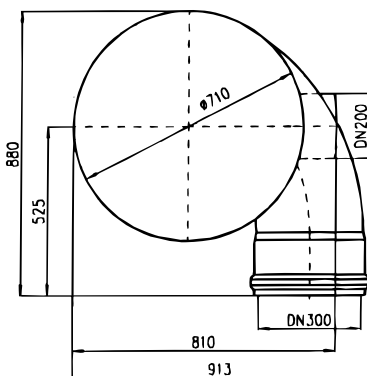
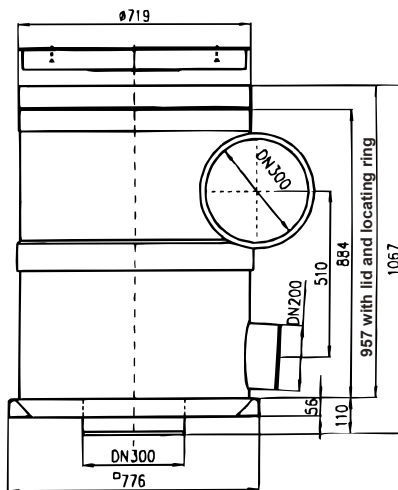
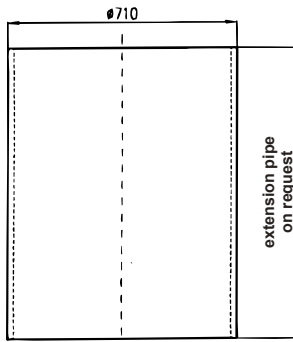
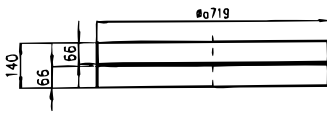

*) DN = Nominal diameter, short for nominal size = approx. internal diameter of a pipe.

Guarantee

The WFF is carefully manufactured and subjected to strict quality controls. Should faults be found, we will provide a replacement. This does not apply to damage caused during installation. We give a 2 year guarantee as from the date of purchase.

Installing the filter unit in the ground

- remove steel inspection cover
- remove the internal packing materials

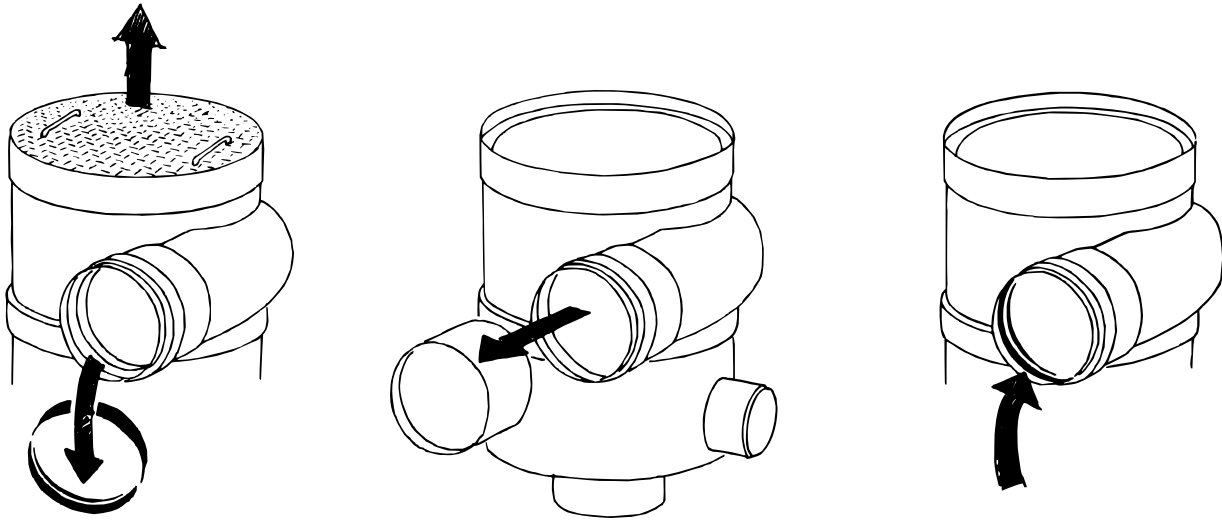

- remove the pipe bung from the rainwater inlet pipe. To do this remove the rubber seal from the mouth of the inlet. Push the bung out from the inside and then replace the rubber seal.
- Do not remove the lid from the pipe bung as this protects the inside of the unit when backfilling with sand.

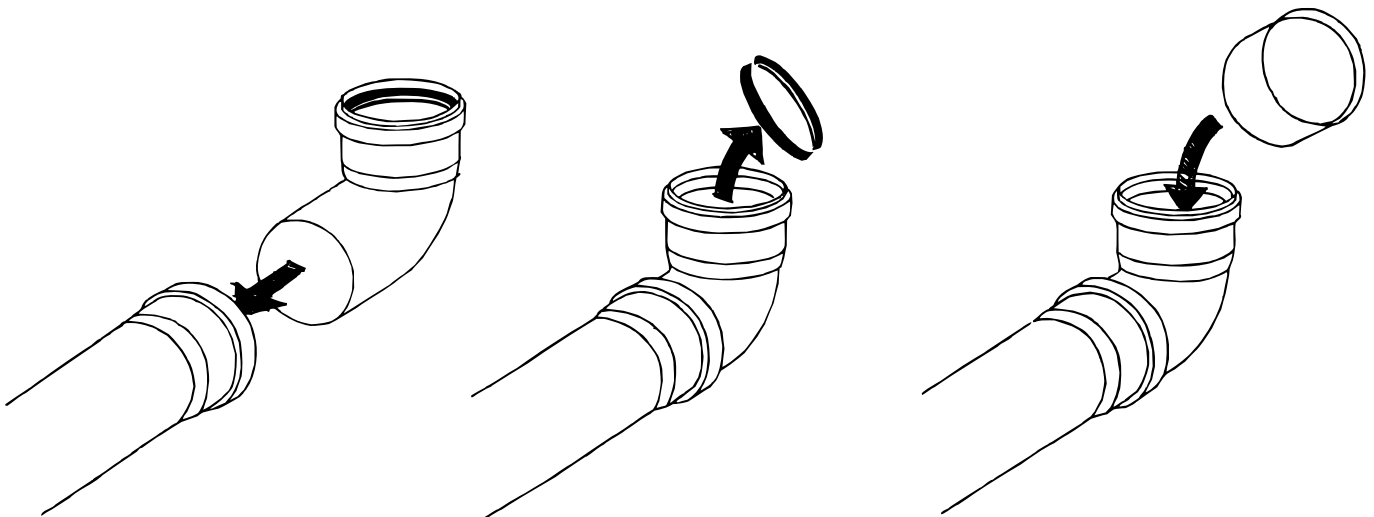

- The pipe that will carry the waste water to drain connects to the outlet beneath the unit. This pipe must have a 90-degree bend attached in order to meet the filter outlet. The pipe bung should be inserted in the open end of the 90-degree bend, having first removed the rubber seal. The bung will prevent debris from falling into the pipe during the installation process.

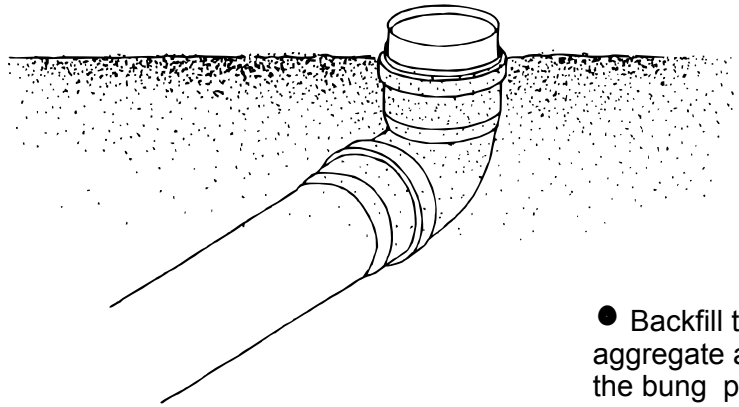

- Backfill the waste pipe trench with appropriate compacted aggregate as normal, leaving the end of the 90-degree bend with the bung protruding.

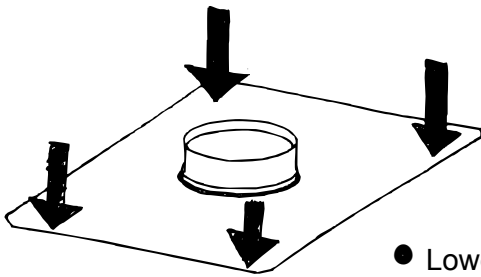

- Lower the steel base plate over the end of the pipe and position it dead flat on to the sand base. Ensure that the base plate is completely flat and that there are no cavities beneath it.

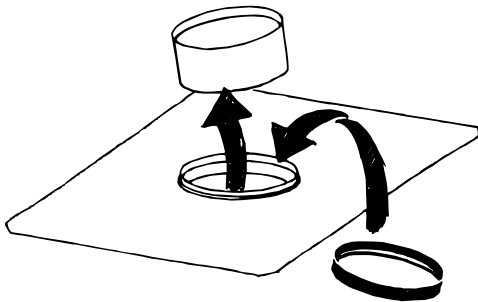

- Remove the pipe bung and insert the rubber seal removed earlier back into its position.

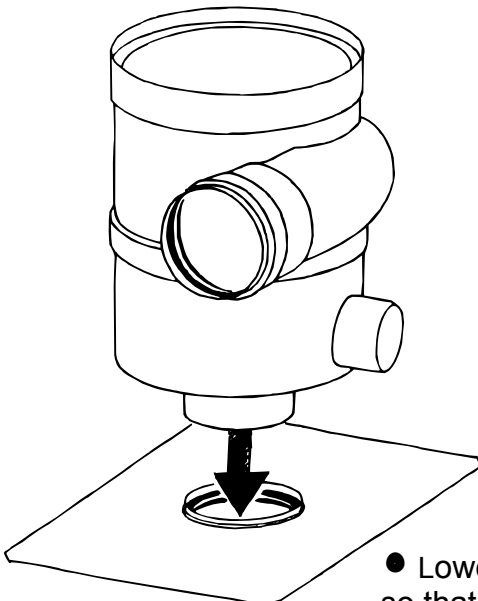

- Lower the WFF300 unit carefully over the end of the pipe so that it rests flat and evenly on the base plate

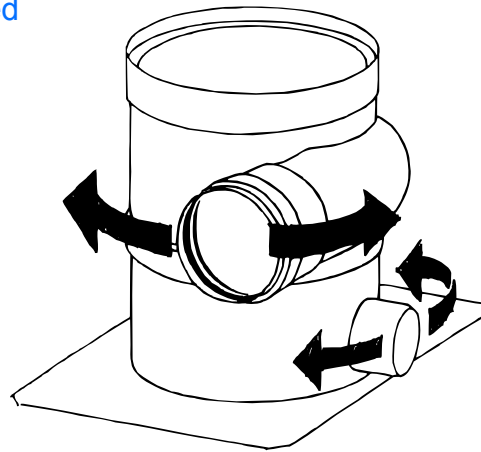
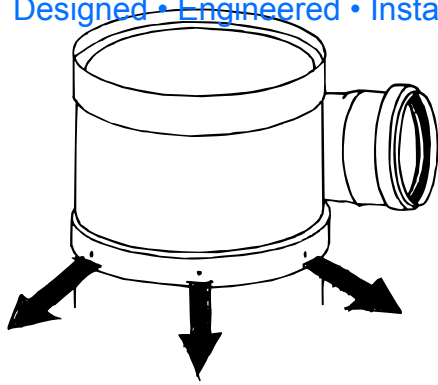

- Align the rainwater inlet and the clean water outlets of the filter to face the desired directions to meet the relevant pipework. To achieve this, first unscrew the retaining screws from the 'waist' of the unit where the top ring overlaps the bottom.

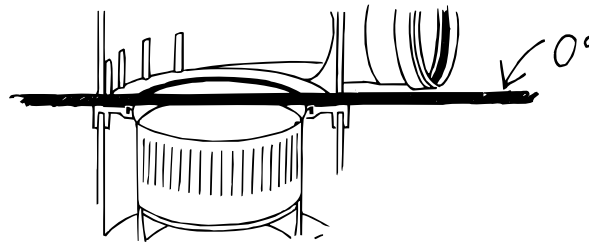
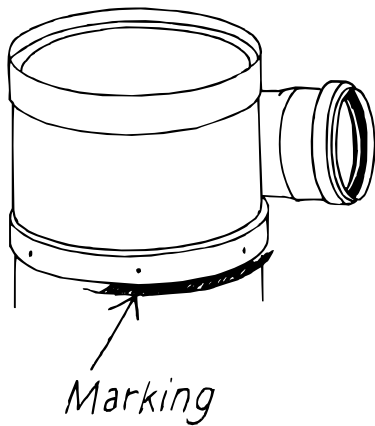

- Having aligned the filter correctly, the two halves of the unit must now be checked to ensure that they meet properly. This is when the mark below the upper housing ring is visible to exactly the same extent all the way around the unit.

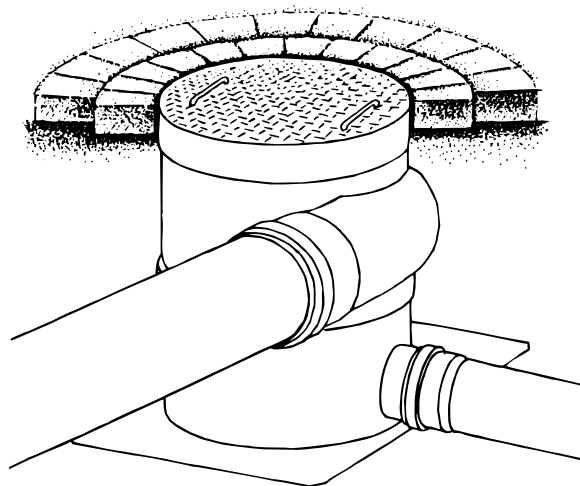
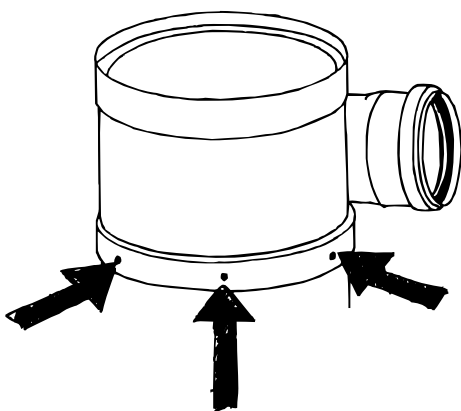

- Refit the retaining screws to secure the two halves of the filter. Connect the rainwater inlet pipe and the clean water outlet pipe to the filter. The WFF300 filter is now ready for use.

Maintenance

- The housing of the WFF is maintenance-free. It consists of non-corrosive plastic. The filter mesh is virtually self-cleaning by the action of water flowing over the vertical mesh. Nevertheless a thin film will build up on the mesh over a period of time. Usually this does not effect the efficiency of the appliance, but we nevertheless recommend taking out the filter insert from time to time and spraying any pores that have become clogged, from the inside with a strong jet of water (garden spray or high-pressure cleaner). Cleaning can also be carried out by hand with the help of a small brush (not a wire brush) and normal washing up liquid.

- Taking out the filter element:

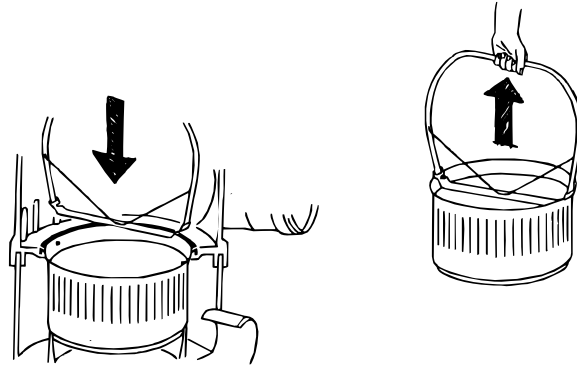

1. Take the lifting handle and lower it on to the top of the filter element, positioning the flat part under the locating lugs.
2. Lift out the filter element.
3. The filter handle should always be removed after use and stored away safely. If left resting on the filter element, it will impede the water flow and thereby lower the efficiency of the filter.

Accessories

Blind insert

- The blind insert provides a direct flow of rainwater into the drain.

Extension piece

- Extension pipes are available for the installation of the WFF 300 into deeper ground. These raise the inspection opening to ground level. They are slotted onto the final ring, which then acts as intermediate ring. The extension pipes are fitted with a final ring on one side to provide for the insertion of the manhole cover and make paving around the cover possible.

Lifting handle

- The lifting handle that is supplied with the filter unit is sufficient to lift the filter element out from an inspection opening that has been raised up to 50 cm. For those WFF that are installed at a deeper level, handles are available for the respective lengths.

Supporting frame

- For indoor installation of the WFF300 a stainless steel mounting frame is available. Fixing devices can be manufactured by WISY which are matched to special application areas.

Damage in transit

WISY products are carefully checked before dispatch, but the risk of damage during transport cannot be guaranteed.

- Check the goods for content and damage on receipt.
- Any damage is the responsibility of the carrier, register any claim with them immediately.
- Contact **your supplier** before returning **any goods**.